

Asymptotic analysis of finite-source M/M/1 retrial queueing system with collisions and server subject to breakdowns and repairs

Anatoly Nazarov¹ · János Sztrik² · Anna Kvach¹ · Tamás Bérczes²

© Springer Science+Business Media, LLC, part of Springer Nature 2018

Abstract The aim of the present paper is to investigate a finite-source M/M/1 retrial queueing system with collision of the customers where the server is subjects to random breakdowns and repairs depending on whether it is idle or busy. An asymptotic method is applied under the condition that the number of sources tends to infinity while the primary request generation rate, retrial rate tend to zero and service rate, failure rates, repair rate are fixed. It is proved that in steady state the limiting distribution of the centered and normalized number of customers in the system (orbit and service) follows a normal law with given parameters. The novelty of this investigation is the introduction of failure and repair of the service. Approximations of prelimiting distribution by asymptotic one are obtained and several illustrative examples show the accuracy and range of applicability of the proposed method.

Keywords Finite-source queueing system · Retrial queue · Collision · Server breakdowns and repairs · Asymptotic analysis · Limiting distribution · Approximation of distributions · Accuracy and area of applicability of approximations

1 Introduction

Retrial queues have been widely used to model many problems arising in telephone switching systems, telecommunication networks, computer networks and computer systems, call

✉ János Sztrik
sztrik.janos@inf.unideb.hu

Anatoly Nazarov
nazarov.tsu@gmail.com

Anna Kvach
kvach_as@mail.ru

Tamás Bérczes
berczes.tamas@inf.unideb.hu

¹ National Research Tomsk State University, 36 Lenina ave., Tomsk, Russia 634050

² University of Debrecen, Debrecen, Hungary

centers, wireless communication systems, etc. For a systematic account of the fundamental methods and the latest results, furthermore an accessible classified bibliography on this topic the interested reader is referred to, for example Arivudainambi and Godhandaraman (2015), Artalejo and Gómez-Corral (2008), Gómez-Corral and Phung-Duc (2016) and Kim and Kim (2016), and references therein.

In many practical situations it is important to take into account the fact that the rate of generation of new primary calls decreases as the number of customers in the system increases. This can be done with the help of finite-source, or quasi-random input models. Retrial queues with quasi-random input are recent interest in modeling magnetic disk memory systems, cellular mobile networks, computer networks, and local-area networks with non-persistent CSMA/CD protocols, with star topology, with random access protocols, and with multiple-access protocols, see for example Bae et al. (2008), Dragieva (2016) and Kumar et al. (2016).

Since in practice some components of the systems are subject to random breakdowns it is of basic importance to study reliability of retrial queues with server breakdowns and repairs because of limited ability of repairs and heavy influence of the breakdowns on the performance measures of the system. Finite-source retrial queues with an unreliable server have been investigated in several recent papers, see for example, Almási et al. (2005), Dragieva (2014), Gharbi and Dutheillet (2011), Ikhlef et al. (2016), Roszik (2004), Wang et al. (2010), Wang et al. (2011) and Zhang and Wang (2013).

In many situations involving data transmission from diverse sources there can be conflict for a limited number of channels or other facilities. Uncoordinated attempts by several sources to use a single server facility can result in collisions leading to the loss of the transmission and hence the need for retransmission. An important problem concerns the development of workable procedures for alleviating the conflict and corresponding message delay. For instance, in the unslotted Carrier Sense Multiple Access with Collision Detection (CSMA–CD) protocols for a fiber optic bus network with a finite number of stations, each of which has an infinite storage buffer, the collisions occur during the transmission of arbitrary length packets because no slot synchronization is needed. Also, because of the unidirectional transmission property of an optical fiber, a solution always has the preference of accessing the channel to its downstream stations. Thus we treat this network as a retrial queueing system with collisions. Recent results on retrial queues with collisions can be found in, for example Ali and Wei (2015), Balsamo et al. (2013), Choi et al. (1992), Gómez-Corral (2010), Kim (2010), Kumar et al. (2010), Kumar et al. (2010) and Peng et al. (2014).

The aim of the present paper is to investigate such systems which has the above mention properties, that is finite-source, retrial, collision, and non-reliability of the server. The present model is a generalization of the systems treated in Kvach and Nazarov (2015), Nazarov et al. (2014), Nazarov and Sudyko (2010) and Nazarov and Moiseeva (2006).

The rest of the paper is organized as follows. In Sections 2 and 3 the full description of the model is given by the help of the corresponding two-dimensional Markov chain and the corresponding Kolmogorov equations are derived in steady state. Sections 4 and 5 are devoted to the first and second order asymptotics. In Sect. 6 an algorithmic approach is proposed to get the prelimiting distribution of the number of customers in the system. Section 7 deals with several numerical examples and comparisons showing the advantage of the asymptotic methods, and some comments are made. Finally, the paper ends with a Conclusion.

Fig. 1 Finite-source M/M/1 retrial queueing system with collision of the customers and an unreliable server

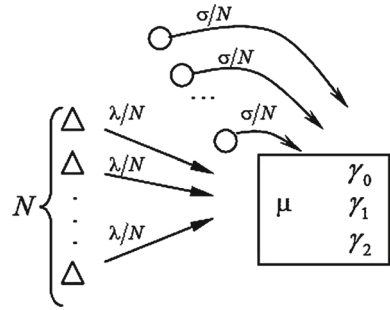

2 Model description and notations

Let us consider (Fig. 1) a retrial queueing system of type $M/M/1//N$ with collision of the customers and an unreliable server. The number of sources is N and each of them can generate a primary request with rate λ/N . A source cannot generate a new call until the end of the successful service of this customer. If a primary customer finds the server idle, he enters into service immediately, in which the required service time is assumed to be exponentially distributed with parameter μ . Otherwise, if the server is busy, an arriving (primary or repeated) customer involves into collision with the customer under service and they both moves into the orbit. The retrial time of requests are exponentially distribution with rate σ/N . We assume that the server is unreliable, that is the lifetime is supposed to be exponentially distributed with failure rate γ_0 if the server is idle and with rate γ_1 if it is busy. When the server breaks down, it is immediately sent for repair and the recovery time is assumed to be exponentially distributed with rate γ_2 . We deal with the case when the server is down all sources continue generation of customers and send it to the server, similarly customers may retry from the orbit to the server but all arriving customers immediately go into the orbit. Furthermore, in this unreliable model we suppose the interrupted request goes to the orbit immediately and its next service is independent of the interrupted one. All random variables involved in the model construction are assumed to be independent of each other.

Let $i(t)$ be the number of customers in the system at time t , that is, the total number of customers in the orbit and in service. Similarly, let $k(t)$ be the server state at time t , that is

$$k(t) = \begin{cases} 0, & \text{if the server is idle,} \\ 1, & \text{if the server is busy,} \\ 2, & \text{if the server is down (under repair).} \end{cases}$$

The aim of the present paper is to find the limiting probability distribution of the number of customers in the system $\{i(t)\}$ in steady state under the conditions of $N \rightarrow \infty$. Hence we can give an approximation of the prelimiting probability distribution for finite values of N by the help of the asymptotic distribution. Then the accuracy of this approximation for finite values of N are illustrated for different input parameters.

3 Kolmogorov equations for the probability distribution

Let us denote by $P\{k(t) = k, i(t) = i\} = P_k(i, t)$ the joint probability that at time t there are i customers in the system and the server is in state k . Under the above assumption the process $\{k(t), i(t)\}$ is a 2-dimensional Markov-process with state space $\{0, 1, 2\} \times \{0, 1, \dots, N\}$.

Assume that system is operating in steady state, then for the stationary probability distribution $P_k(i)$ it is not difficult to write the following system of Kolmogorov equations

$$\begin{aligned}
 & - \left[\lambda + (\sigma - \lambda) \frac{i}{N} + \gamma_0 \right] P_0(i) + \left(1 - \frac{i-1}{N} \right) \lambda P_1(i-1) + \frac{i-1}{N} \sigma P_1(i) \\
 & \quad + \mu P_1(i+1) + \gamma_2 P_2(i) = 0, \\
 & - \left[\lambda + (\sigma - \lambda) \frac{i}{N} + \gamma_1 + \mu - \frac{\sigma}{N} \right] P_1(i) + \left(1 - \frac{i-1}{N} \right) \lambda P_0(i-1) \\
 & \quad + \frac{i}{N} \sigma P_0(i) = 0, \\
 & - \left[\left(1 - \frac{i}{N} \right) \lambda + \gamma_2 \right] P_2(i) + \left(1 - \frac{i-1}{N} \right) \lambda P_2(i-1) \\
 & \quad + \gamma_0 P_0(i) + \gamma_1 P_1(i) = 0.
 \end{aligned} \tag{1}$$

Denoting the partial characteristic function by

$$H_k(u) = \sum_{i=0}^N e^{ju_i} P_k(i), \tag{2}$$

where $j = \sqrt{-1}$ is the imaginary unit, the system (1) can be rewritten as

$$\begin{aligned}
 & - (\lambda + \gamma_0) H_0(u) + \left[\lambda e^{ju} + \mu e^{-ju} - \frac{\sigma}{N} \right] H_1(u) + \gamma_2 H_2(u) \\
 & \quad + j \frac{(\sigma - \lambda)}{N} H_0'(u) + j \frac{(\lambda e^{ju} - \sigma)}{N} H_1'(u) = 0, \\
 & \lambda e^{ju} H_0(u) - \left(\lambda + \mu + \gamma_1 - \frac{\sigma}{N} \right) H_1(u) \\
 & \quad + j \frac{(\lambda e^{ju} - \sigma)}{N} H_0'(u) + j \frac{(\sigma - \lambda)}{N} H_1'(u) = 0, \\
 & \gamma_0 H_0(u) + \gamma_1 H_1(u) + \left[\lambda (e^{ju} - 1) - \gamma_2 \right] H_2(u) \\
 & \quad + j \frac{\lambda}{N} (e^{ju} - 1) H_2'(u) = 0.
 \end{aligned} \tag{3}$$

Summarizing the equations of the system (3) we obtain

$$\begin{aligned}
 & \lambda H_0(u) + \left[\lambda - \mu e^{-ju} \right] H_1(u) + \lambda H_2(u) \\
 & \quad + j \frac{\lambda}{N} \left[H_0'(u) + H_1'(u) + H_2'(u) \right] = 0.
 \end{aligned} \tag{4}$$

The solution of the system (3–4) for finite values N causes difficulties, namely the authors do not know any method for solving systems of linear differential equations with variable coefficients. In addition, to the best knowledge of the authors such systems do not have an analytical solution therefore we will find solution under the condition of unlimited growing number of sources, that is $N \rightarrow \infty$.

4 Asymptotic of the first order

Theorem 1 Let $i(\infty)$ be the number of customers in the system in steady state, then

$$\lim_{N \rightarrow \infty} E \exp \left\{ jw \frac{i(\infty)}{N} \right\} = \exp \{ jw \kappa_1 \}, \quad (5)$$

where value of parameter κ_1 is the positive solution of the equation

$$(1 - \kappa_1) \lambda - \mu R_1(\kappa_1) = 0, \quad (6)$$

where the stationary distributions of probabilities $R_k(\kappa_1)$ of the service state k are obtained as follows

$$\begin{aligned} R_0(\kappa_1) &= \left\{ \frac{\gamma_0 + \gamma_2}{\gamma_2} + \frac{\gamma_1 + \gamma_2}{\gamma_2} \cdot \frac{a(\kappa_1)}{a(\kappa_1) + \gamma_1 + \mu} \right\}^{-1}, \\ R_1(\kappa_1) &= \frac{a(\kappa_1)}{a(\kappa_1) + \gamma_1 + \mu} \cdot R_0(\kappa_1), \\ R_2(\kappa_1) &= \frac{1}{\gamma_2} [\gamma_0 R_0(\kappa_1) + \gamma_1 R_1(\kappa_1)], \end{aligned} \quad (7)$$

here $a(\kappa_1)$ is

$$a(\kappa_1) = (1 - \kappa_1) \lambda + \sigma \kappa_1. \quad (8)$$

Proof Denoting $\frac{1}{N} = \varepsilon$, in systems (3–4) let us execute the following substitutions

$$u = \varepsilon w, \quad H_k(u) = F_k(w, \varepsilon), \quad (9)$$

then we can transform systems (3–4) to the form

$$\begin{aligned} -(\lambda + \gamma_0) F_0(w, \varepsilon) + \left[\lambda e^{j\varepsilon w} + \mu e^{-j\varepsilon w} - \varepsilon \sigma \right] F_1(w, \varepsilon) + \gamma_2 F_2(w, \varepsilon) \\ + j(\sigma - \lambda) \frac{\partial F_0(w, \varepsilon)}{\partial w} + j(\lambda e^{j\varepsilon w} - \sigma) \frac{\partial F_1(w, \varepsilon)}{\partial w} = 0, \\ \lambda e^{j\varepsilon w} F_0(w, \varepsilon) - (\lambda + \mu + \gamma_1 - \varepsilon \sigma) F_1(w, \varepsilon) \\ + j(\lambda e^{j\varepsilon w} - \sigma) \frac{\partial F_0(w, \varepsilon)}{\partial w} + j(\sigma - \lambda) \frac{\partial F_1(w, \varepsilon)}{\partial w} = 0, \\ \gamma_0 F_0(w, \varepsilon) + \gamma_1 F_1(w, \varepsilon) + \left[\lambda (e^{j\varepsilon w} - 1) - \gamma_2 \right] F_2(w, \varepsilon) \\ + j\lambda (e^{j\varepsilon w} - 1) \frac{\partial F_2(w, \varepsilon)}{\partial w} = 0, \\ \lambda F_0(w, \varepsilon) + \left[\lambda - \mu e^{-j\varepsilon w} \right] F_1(w, \varepsilon) + \lambda F_2(w, \varepsilon) \\ + j\lambda \frac{\partial}{\partial w} [F_0(w, \varepsilon) + F_1(w, \varepsilon) + F_2(w, \varepsilon)] = 0. \end{aligned} \quad (10)$$

Taking the limiting transition under conditions $\varepsilon \rightarrow 0$ and denoting $\lim_{\varepsilon \rightarrow 0} F_k(w, \varepsilon) = F_k(w)$, system (10) can be rewritten as

$$\begin{aligned}
& -(\lambda + \gamma_0) F_0(w) \\
& + (\lambda + \mu) F_1(w) + \gamma_2 F_2(w) \\
& + j(\sigma - \lambda) F_0'(w) + j(\lambda - \sigma) F_1'(w) = 0, \\
& \lambda F_0(w) - (\lambda + \mu + \gamma_1) F_1(w) + j(\lambda - \sigma) F_0'(w) + j(\sigma - \lambda) F_1'(w) = 0, \\
& \gamma_0 F_0(w) + \gamma_1 F_1(w) - \gamma_2 F_2(w) = 0, \\
& \lambda F_0(w) + (\lambda - \mu) F_1(w) + \lambda F_2(w) + j\lambda \frac{d}{dw} [F_0(w) + F_1(w) + F_2(w)] = 0. \quad (11)
\end{aligned}$$

From previous experience we want to find the solution of system (11) in the following product-form

$$F_k(w) = R_k \Phi(w),$$

where R_k is the limiting probability distributions of the server state k under conditions $N \rightarrow \infty$ and $\Phi(w)$ is the limiting characteristic function of the stationary distribution of the normalized number of customers in the system. Substituting into (11) we obtain

$$\begin{aligned}
& -(\lambda + \gamma_0) R_0 \\
& + (\lambda + \mu) R_1 + \gamma_2 R_2 + j(\sigma - \lambda) (R_0 - R_1) \frac{\Phi'(w)}{\Phi(w)} = 0, \\
& \lambda R_0 - (\lambda + \mu + \gamma_1) R_1 + j(\sigma - \lambda) (R_1 - R_0) \frac{\Phi'(w)}{\Phi(w)} = 0, \\
& \gamma_0 R_0 + \gamma_1 R_1 - \gamma_2 R_2 = 0, \\
& \lambda R_0 + (\lambda - \mu) R_1 + \lambda R_2 + j\lambda (R_0 + R_1 + R_2) \frac{\Phi'(w)}{\Phi(w)} = 0, \quad (12)
\end{aligned}$$

from which it follows that the function has the form

$$\Phi(w) = \exp(jw\kappa_1), \quad (13)$$

coinciding with equality (5). This statement is actually the law of large numbers and κ_1 is the expectation of the normalized number of customers in the system or in other words it is the steady state probability that a customer is in the system.

The next step is to find κ_1 . Knowing the probabilistic meaning of κ_1 it is natural to introduce the following notation $a(\kappa_1) = (1 - \kappa_1)\lambda + \sigma\kappa_1$ which in probabilistic sense is the mean offered arrival rate to the server. Then system (12) can be rewritten as

$$\begin{aligned}
& -[a(\kappa_1) + \gamma_0] R_0(\kappa_1) \\
& + [a(\kappa_1) + \mu] R_1(\kappa_1) + \gamma_2 R_2(\kappa_1) = 0, \\
& a(\kappa_1) R_0(\kappa_1) - [a(\kappa_1) + \mu + \gamma_1] R_1(\kappa_1) = 0, \\
& \gamma_0 R_0(\kappa_1) + \gamma_1 R_1(\kappa_1) - \gamma_2 R_2(\kappa_1) = 0, \\
& (1 - \kappa_1)\lambda - \mu R_1(\kappa_1) = 0. \quad (14)
\end{aligned}$$

It is easy to see that they are the balance equations. The first three equations of this system are compatible, one equation is a consequence of the other two. Therefore, the solution (7) can be found using two equations of three and then applying the normalization condition the solution can be obtained.

The value of parameter κ_1 is defined as the solution of the fourth equation of system (14) and this equation coincides with (6), which has a natural interpretation, namely the mean arrival rate to the systems is equal to the mean departure rate from the system.

Keeping in mind the notation $\frac{1}{N} = \varepsilon$, replacement (9) and equations (13), the main equality (5) of the theorem is obtained.

The theorem is proved. □

This theorem is called the first order asymptotics for the closed retrial queuing systems.

Corollary 1 *The prelimiting value of the average number of customers in this closed retrial queuing system can be approximated by expression*

$$E \{i(\infty)\} \approx N\kappa_1, \tag{15}$$

obviously follows from the Eq. (5).

If for the simplified notation $a(\kappa_1)$ and probabilities $R_k(\kappa_1)$ are denoted by a and R_k , respectively, then (6–8) can be rewritten as

$$\begin{aligned} \mu R_1 &= (1 - \kappa_1) \lambda, \\ R_0 &= \left\{ \frac{\gamma_0 + \gamma_2}{\gamma_2} + \frac{\gamma_1 + \gamma_2}{\gamma_2} \cdot \frac{a}{a + \gamma_1 + \mu} \right\}^{-1}, \\ R_1 &= R_0 \frac{a}{a + \gamma_1 + \mu}, \\ R_2 &= \frac{1}{\gamma_2} [\gamma_0 R_0 + \gamma_1 R_1], \end{aligned} \tag{16}$$

where

$$a = (1 - \kappa_1) \lambda + \sigma \kappa_1.$$

5 Asymptotic of the second order

To get a better approximation of the prelimiting distribution of customers in the system for a finite N we need the following theorem concerning to the variance.

Theorem 2 *Under the conditions of Theorem 1 we have*

$$\lim_{N \rightarrow \infty} E \exp \left\{ jw \frac{i(\infty) - \kappa_1 N}{\sqrt{N}} \right\} = \exp \left\{ \frac{(jw)^2}{2} \kappa_2 \right\}, \tag{17}$$

where the value of parameter κ_2 is defined by expression

$$\kappa_2 = \frac{\gamma_2 \mu (R_1 - b_1) + (1 - \kappa_1) \lambda \{(\gamma_1 + \gamma_2) b_1 + (1 - \kappa_1) \lambda R_2\}}{(\lambda + \mu b_2) \gamma_2 - (1 - \kappa_1) \lambda (\gamma_1 + \gamma_2) b_2}, \tag{18}$$

where

$$b_1 = \frac{(1 - \kappa_1) \lambda}{a + \gamma_1 + \mu}, \quad b_2 = \frac{(\sigma - \lambda)(R_0 - R_1)}{a + \gamma_1 + \mu}. \tag{19}$$

Proof Introducing the following replacement

$$H_k(u) = H_k^{(2)}(u) e^{juN\kappa_1}, \tag{20}$$

in the systems (3–4) for function $H_k^{(2)}$ we obtain the system of equations in the form

$$\begin{aligned}
 & -[\lambda + \gamma_0 + (\sigma - \lambda) \kappa_1] H_0^{(2)}(u) \\
 & + \left[\lambda e^{ju} + \mu e^{-ju} + (\sigma - \lambda e^{ju}) \kappa_1 - \frac{\sigma}{N} \right] H_1^{(2)}(u) + \gamma_2 H_2^{(2)}(u) \\
 & + j \frac{(\sigma - \lambda)}{N} H_0^{(2)'}(u) + j \frac{(\lambda e^{ju} - \sigma)}{N} H_1^{(2)'}(u) = 0, \\
 & \left[\lambda e^{ju} + (\sigma - \lambda e^{ju}) \kappa_1 \right] H_0^{(2)}(u) \\
 & - \left[\lambda + \mu + \gamma_1 + (\sigma - \lambda) \kappa_1 - \frac{\sigma}{N} \right] H_1^{(2)}(u) \\
 & + j \frac{(\lambda e^{ju} - \sigma)}{N} H_0^{(2)'}(u) + j \frac{(\sigma - \lambda)}{N} H_1^{(2)'}(u) = 0, \\
 & \gamma_0 H_0^{(2)}(u) + \gamma_1 H_1^{(2)}(u) + \left[\lambda (1 - \kappa_1) (e^{ju} - 1) - \gamma_2 \right] H_2^{(2)}(u) \\
 & + j \frac{\lambda}{N} (e^{ju} - 1) H_2^{(2)'}(u) = 0, \\
 & \lambda (1 - \kappa_1) \left[H_0^{(2)}(u) + H_1^{(2)}(u) + H_2^{(2)}(u) \right] - \mu e^{-ju} H_1^{(2)}(u) \\
 & + j \frac{\lambda}{N} \frac{d}{du} \left[H_0^{(2)}(u) + H_1^{(2)}(u) + H_2^{(2)}(u) \right] = 0. \tag{21}
 \end{aligned}$$

Let us introduce the following replacements

$$\frac{1}{N} = \varepsilon^2, \quad u = \varepsilon w, \quad H_k^{(2)}(u) = F_k^{(2)}(w, \varepsilon). \tag{22}$$

Note that in the asymptotic of the second order the same designation of $F_k^{(2)}(w, \varepsilon)$ is applied, as in the first asymptotic, but as it will be shown below these functions keeping an identical look, differ with the defining multiplicand.

Carrying out replacements (22) in the system (21), we obtain the following system of equations

$$\begin{aligned}
 & -[\lambda + \gamma_0 + (\sigma - \lambda) \kappa_1] F_0^{(2)}(w, \varepsilon) + \gamma_2 F_2^{(2)}(w, \varepsilon) \\
 & + \left[\lambda e^{j\varepsilon w} + e^{-j\varepsilon w} + (\sigma - \lambda e^{j\varepsilon w}) \kappa_1 - \varepsilon^2 \sigma \right] F_1^{(2)}(w, \varepsilon) \\
 & + \varepsilon j (\sigma - \lambda) \frac{\partial F_0^{(2)}(w, \varepsilon)}{\partial w} + \varepsilon j (\lambda e^{j\varepsilon w} - \sigma) \frac{\partial F_1^{(2)}(w, \varepsilon)}{\partial w} = 0, \\
 & \left[\lambda e^{j\varepsilon w} + (\sigma - \lambda e^{j\varepsilon w}) \kappa_1 \right] F_0^{(2)}(w, \varepsilon) \\
 & - \left[\lambda + \mu + \gamma_1 + (\sigma - \lambda) \kappa_1 - \varepsilon^2 \sigma \right] F_1^{(2)}(w, \varepsilon) \\
 & + \varepsilon j (\lambda e^{j\varepsilon w} - \sigma) \frac{\partial F_0^{(2)}(w, \varepsilon)}{\partial w} + \varepsilon j (\sigma - \lambda) \frac{\partial F_1^{(2)}(w, \varepsilon)}{\partial w} = 0, \\
 & \gamma_0 F_0^{(2)}(w, \varepsilon) + \gamma_1 F_1^{(2)}(w, \varepsilon) + \left[\lambda (1 - \kappa_1) (e^{j\varepsilon w} - 1) - \gamma_2 \right] F_2^{(2)}(w, \varepsilon) \\
 & + \varepsilon j \lambda (e^{j\varepsilon w} - 1) \frac{\partial F_2^{(2)}(w, \varepsilon)}{\partial w} = 0,
 \end{aligned}$$

$$\lambda (1 - \kappa_1) \left[F_0^{(2)}(w, \varepsilon) + F_1^{(2)}(w, \varepsilon) + F_2^{(2)}(w, \varepsilon) \right] - \mu e^{-j\varepsilon w} F_1^{(2)}(w, \varepsilon) + \varepsilon j \lambda \frac{\partial}{\partial w} \left[F_0^{(2)}(w, \varepsilon) + F_1^{(2)}(w, \varepsilon) + F_2^{(2)}(w, \varepsilon) \right] = 0. \tag{23}$$

The solution of this system can be written in the form of decomposition

$$F_k^{(2)}(w, \varepsilon) = \Phi_2(w) \{R_k + j\varepsilon w f_k\} + o(\varepsilon^2),$$

then after substituting them into (23), we obtain

$$\begin{aligned} &-(a + \gamma_0) [R_0 + j\varepsilon w f_0] + j\varepsilon w (a + \mu) f_1 + \gamma_2 \{R_2 + j\varepsilon w f_2\} \\ &+ \{\lambda (1 + j\varepsilon w) + \mu (1 - j\varepsilon w) + [\sigma - \lambda (1 + j\varepsilon w)] \kappa_1\} R_1 \\ &+ \varepsilon j (\sigma - \lambda) (R_0 - R_1) \frac{\Phi_2'(w)}{\Phi_2(w)} = o(\varepsilon^2), \\ &\{\lambda (1 + j\varepsilon w) + [\sigma - \lambda (1 + j\varepsilon w)] \kappa_1\} R_0 - (a + \gamma_1 + \mu) \{R_1 + j\varepsilon w f_1\} \\ &+ j\varepsilon w a f_0 + \varepsilon j (\sigma - \lambda) (R_1 - R_0) \frac{\Phi_2'(w)}{\Phi_2(w)} = o(\varepsilon^2), \\ &\gamma_0 \{R_0 + j\varepsilon w f_0\} + \gamma_1 \{R_1 + j\varepsilon w f_1\} + \{j\varepsilon w \lambda (1 - \kappa_1) - \gamma_2\} R_2 \\ &- j\varepsilon w \gamma_2 f_2 = o(\varepsilon^2), \\ &\lambda (1 - \kappa_1) \{1 + j\varepsilon w (f_0 + f_1 + f_2)\} - \mu (1 - j\varepsilon w) R_1 - j\varepsilon w \mu f_1 \\ &+ \varepsilon j \lambda \frac{\Phi_2'(w)}{\Phi_2(w)} = o(\varepsilon^2). \end{aligned}$$

Equating here coefficients at identical degrees ε , relatively f_k , we will receive the following system of equations

$$\begin{aligned} &-(a + \gamma_0) f_0 + (a + \mu) f_1 + \gamma_2 f_2 = [\mu - (1 - \kappa_1) \lambda] R_1 \\ &- (\sigma - \lambda) (R_0 - R_1) \frac{\Phi_2'(w)}{w \Phi_2(w)}, \\ &a f_0 - (a + \gamma_1 + \mu) f_1 = -(1 - \kappa_1) \lambda R_0 - (\sigma - \lambda) (R_1 - R_0) \frac{\Phi_2'(w)}{w \Phi_2(w)}, \tag{24} \\ &\gamma_0 f_0 + \gamma_1 f_1 - \gamma_2 f_2 = -(1 - \kappa_1) \lambda R_2, \\ &\lambda (1 - \kappa_1) [f_0 + f_1 + f_2] - \mu f_1 = -\mu R_1 - \lambda \frac{\Phi_2'(w)}{w \Phi_2(w)}. \end{aligned}$$

Hence function $\Phi_2(w)$ can be written as

$$\Phi_2(w) = \exp \left\{ \frac{(jw)^2}{2} \kappa_2 \right\},$$

coinciding with (17).

Therefore the expression $\frac{\Phi_2'(w)}{w \Phi_2(w)}$ is constant and has the form

$$\frac{\Phi_2'(w)}{w \Phi_2(w)} = -\kappa_2 \quad (25)$$

which should be determined. Owing to (25), (24) results a heterogeneous system of linear equations with respect to f_k and can be rewritten as

$$\begin{aligned} -(a + \gamma_0) f_0 + (a + \mu) f_1 + \gamma_2 f_2 &= [\mu - (1 - \kappa_1) \lambda] R_1 \\ &\quad + (\sigma - \lambda) (R_0 - R_1) \kappa_2, \\ a f_0 - (a + \gamma_1 + \mu) f_1 &= -(1 - \kappa_1) \lambda R_0 + (\sigma - \lambda) (R_1 - R_0) \kappa_2, \\ \gamma_0 f_0 + \gamma_1 f_1 - \gamma_2 f_2 &= -(1 - \kappa_1) \lambda R_2, \\ \lambda (1 - \kappa_1) [f_0 + f_1 + f_2] - \mu f_1 &= -\mu R_1 + \lambda \kappa_2. \end{aligned} \quad (26)$$

The first three equations from (26) constitute a heterogeneous system of linear equations with system determinant equal to zero. But as the ranks of the matrix of the homogeneous system and of the augmented matrix are the same, then the system has a general solution of the form

$$f_k = C R_k + \varphi_k, \quad (27)$$

where φ_k is a particular solution, determined by some additional conditions.

Substituting the general solution (27) into the fourth equation of system (26), we get

$$(1 - \kappa_1) \lambda [C + \varphi_0 + \varphi_1 + \varphi_2] - \mu [C R_1 + \varphi_1] = -\mu R_1 + \lambda \kappa_2. \quad (28)$$

Owing to the first equality from (16), equality (28) can be rewritten in the form

$$(1 - \kappa_1) \lambda [\varphi_0 + \varphi_1 + \varphi_2] - \mu \varphi_1 = -\mu R_1 + \lambda \kappa_2. \quad (29)$$

The received equality defines the value of the parameter κ_2 , which naturally doesn't depend on the values of the arbitrary constant C and it is the same for any particular solutions, defined by some additional conditions. For convenience we will choose such additional condition in the form of $\varphi_0 = 0$, then equality (29) can be written as

$$(1 - \kappa_1) \lambda [\varphi_1 + \varphi_2] - \mu \varphi_1 = -\mu R_1 + \lambda \kappa_2. \quad (30)$$

Let us rewrite system of three equations for the particular solution φ_k in the form of system of two equations, excepting the first of them

$$\begin{aligned} -(a + \gamma_1 + \mu) \varphi_1 &= -(1 - \kappa_1) \lambda R_0 + (\sigma - \lambda) (R_1 - R_0) \kappa_2, \\ \gamma_1 \varphi_1 - \gamma_2 \varphi_2 &= -(1 - \kappa_1) \lambda R_2. \end{aligned}$$

From this system we obtain

$$\begin{aligned} \varphi_1 &= \frac{(1 - \kappa_1) \lambda}{a + \gamma_1 + \mu} R_0 + \frac{(\sigma - \lambda) (R_0 - R_1)}{a + \gamma_1 + \mu} \kappa_2, \\ \varphi_2 &= \frac{\gamma_1}{\gamma_2} \varphi_1 + \frac{(1 - \kappa_1) \lambda}{\gamma_2} R_2. \end{aligned} \quad (31)$$

Designating

$$b_1 = \frac{(1 - \kappa_1)\lambda}{a + \gamma_1 + \mu} R_0, \quad b_2 = \frac{(\sigma - \lambda)(R_0 - R_1)}{a + \gamma_1 + \mu}, \tag{32}$$

that coincides with (19), equality (31) can be rewritten in the form

$$\begin{aligned} \varphi_1 &= b_1 + \kappa_2 b_2, \\ \varphi_2 &= \frac{\gamma_1}{\gamma_2} (b_1 + \kappa_2 b_2) + \frac{(1 - \kappa_1)\lambda}{\gamma_2} R_2. \end{aligned} \tag{33}$$

Substituting these expressions into (30), we receive the equation concerning to the unknown κ_2

$$\begin{aligned} (1 - \kappa_1)\lambda \left\{ b_1 + \kappa_2 b_2 + \frac{\gamma_1}{\gamma_2} (b_1 + \kappa_2 b_2) + \frac{(1 - \kappa_1)\lambda}{\gamma_2} R_2 \right\} \\ - \mu (b_1 + \kappa_2 b_2) = -\mu R_1 + \lambda \kappa_2, \end{aligned}$$

from which we find the value of the parameter κ_2 as

$$\kappa_2 = \frac{\gamma_2 \mu (R_1 - b_1) + (1 - \kappa_1)\lambda \{(\gamma_1 + \gamma_2) b_1 + (1 - \kappa_1)\lambda R_2\}}{(\lambda + \mu b_2) \gamma_2 - (1 - \kappa_1)\lambda (\gamma_1 + \gamma_2) b_2},$$

coinciding with (18).

The theorem is proved. □

From the proved theorem it follows that if $N \rightarrow \infty$ the limiting distribution for the centered and normalized number of customers in the system has a Gaussian distribution with variance κ_2 , defined by the expression (18).

Consequently, the mean and variance of the number of customers in the system can be approximated by $N\kappa_1$ and $N\kappa_2$, respectively.

Approximation of a discrete distribution by a continuous Gaussian distribution can be executed in various ways. We will use the following form.

Let us denote by $G(x)$ the distribution function of the Gaussian distribution with mean $N\kappa_1$ and variance $N\kappa_2$.

Furthermore, let us denote by $P_N(i)$ the asymptotic discrete distribution obtained by the help of Gaussian approximation, that is

$$P_N(i) = \{G(i + 0.5) - G(i - 0.5)\} [G(N + 0.5) - G(-0.5)]^{-1}, \quad i = \overline{0, N} \tag{34}$$

which is called the Gaussian approximation of the discrete distribution $P(i)$.

Distribution (34) can be considered as an approximation of the prelimiting discrete distribution by the help of the limiting Gaussian distribution.

Let us determine the accuracy (error) of the approximation of a distribution by means of the Kolmogorov's distance Δ which for distribution functions $F_1(x)$ and $F_2(x)$ is defined as

$$\Delta = \max_{-\infty < x < \infty} |F_1(x) - F_2(x)|.$$

If the exact distribution of probabilities $P(n)$ for the number of customers in system is known, then

$$\Delta = \max_{0 \leq i \leq N} \left| \sum_{n=0}^i (P(n) - P_N(n)) \right|.$$

Usually, for complex queueing systems the exact distribution $P(i)$ is usually unknown, so its value we could determine either numerically or by simulation, assuming that these methods are reliable and effective.

Realizing a large enough number of numerical/simulation experiments, we can see the accuracy of approximation and the area of its applicability.

However, in the present situation we are able to get the discrete two-dimensional probability distribution $P_k(i)$ of states $\{k, i\}$ of the considered retrial queueing system by the help of an effective numerical algorithm. For the considered retrial queueing system a simulation program has also been developed and realized, which allows us to build empirical distribution for the number of customers in system. The simulation approach is out of scope of this paper and will be discussed later on as a continuation of the present investigations.

6 Algorithmic approach for finding the probability distribution of the system state (prelimiting distribution for given N)

For the calculation of the two-dimensional probability distribution $P_k(i)$, let us find the solution of system (1) numerically, first writing its equation in the case $i = 0$.

$$-(\lambda + \gamma_0) P_0(0) + \mu P_1(1) + \gamma_2 P_2(0) = 0,$$

$$-(\lambda + \gamma_2) P_2(0) + \gamma_0 P_0(0) = 0.$$

1. Put $P_0(0) = 1$.
2. $P_2(0) = \frac{\gamma_0}{\lambda + \gamma_2} P_0(0)$.
3. $P_1(1) = \frac{1}{\mu} \{(\lambda + \gamma_0) P_0(0) - \gamma_2 P_2(0)\}$.
4. For $1 \leq i \leq N - 1$ from system (1) let us write

$$P_0(i) = \left(\frac{i}{N}\sigma\right)^{-1} \left\{ P_1(i) \left[\lambda + (\sigma - \lambda) \frac{i}{N} + \gamma_1 + \mu - \frac{\sigma}{N} \right] - P_0(i-1) \left(1 - \frac{i-1}{N} \right) \lambda \right\},$$

$$P_2(i) = \left[\left(1 - \frac{i}{N} \right) \lambda + \gamma_2 \right]^{-1} \left\{ \left(1 - \frac{i-1}{N} \right) \lambda P_2(i-1) + \gamma_0 P_0(i) + \gamma_1 P_1(i) \right\},$$

$$P_1(i+1) = \frac{1}{\mu} \left\{ \left[\lambda + (\sigma - \lambda) \frac{i}{N} + \gamma_0 \right] P_0(i) - \left(1 - \frac{i-1}{N} \right) \lambda P_1(i-1) - \frac{(i-1)}{N} \sigma P_1(i) - \gamma_2 P_2(i) \right\}.$$

5. From the system (1) let us write the equation for $i = N$

$$-(\sigma + \gamma_0) P_0(N) + \frac{\lambda}{N} P_1(N-1) + \frac{\sigma}{N} P_1(N) + \gamma_2 P_2(N) = 0,$$

$$-\left(\sigma + \gamma_1 + \mu - \frac{\sigma}{N}\right) P_1(N) + \frac{\lambda}{N} P_0(N-1) + \sigma P_0(N) = 0,$$

$$-\gamma_2 P_2(N) + \frac{\lambda}{N} P_2(N-1) + \gamma_0 P_0(N) + \gamma_1 P_1(N) = 0,$$

from which we get value

$$P_0(N) = \sigma^{-1} \left\{ \left[\sigma + \gamma_1 + \mu - \frac{\sigma}{N} \right] P_1(N) - \frac{\lambda}{N} P_0(N-1) \right\},$$

$$P_2(N) = \gamma_2^{-1} \left\{ \frac{\lambda}{N} P_2(N-1) + \gamma_0 P_0(N) + \gamma_1 P_1(N) \right\}.$$

For the normalizing constant let us calculate the sum

$$d = \sum_{i=0}^N \{P_0(i) + P_1(i) + P_2(i)\},$$

where $P_k(i)$ is the solution of system (1), received by realization of the proposed numerical algorithm, then $d^{-1} P_k(i)$ gives the values of the two-dimensional distribution of probabilities $P_k(i)$.

After the two-dimensional distribution $P_k(i)$ having been defined, we can find one-dimensional marginal distribution of probabilities $P(i)$, the number of i customers in the system as

$$P(i) = P_0(i) + P_1(i) + P_2(i).$$

It should be noted that the initial system can be solved by the traditional method of solving systems of linear algebraic equations, taking into account the degeneracy of the matrix of the system, the existence of a set of solutions, and the allocation of a particular solution satisfying the normalization condition. The dimension of system significantly depends on N and it is necessary to solve system of $3(N+1)$ equations. The recursive algorithm is applicable for sufficiently large values of N , which is an advantage of the proposed algorithmic approach, in comparison to the traditional methods.

7 Numerical results and comparative analysis

For retrieval queuing system of type $M/M/1//N$ with collision and an unreliable server formulas for numerical calculation of probability distribution of the number of customers in the system are received and Gaussian approximation of these discrete preliminary distribution is offered. Let us determine the accuracy and area of applicability of this approximation.

Realizing the proposed numerical algorithm our aim is to show the effect of λ and σ on the approximation. Of course we expect that under a given parameter setup the Kolmogorov distance should decrease as N is increasing. We must emphasize that we cannot expect that by increasing the other parameters the distance will decrease as it is demonstrated later on.

Table 1 Kolmogorov distance between $P(i)$ and $P_N(i)$ for various values of the parameters N and λ

	$N = 5$	$N = 10$	$N = 20$	$N = 30$	$N = 50$
$\lambda = 0.5$	0.095	0.059	0.032	0.023	0.017
$\lambda = 1.0$	0.037	0.023	0.017	0.014	0.011
$\lambda = 2.0$	0.078	0.046	0.022	0.014	0.013

The boldface value in table shows that the acceptable error is less than 0.05

Table 2 Kolmogorov distance between $P(i)$ and $P_N(i)$ for various values of the parameters N and σ

	$N = 5$	$N = 10$	$N = 20$	$N = 30$	$N = 50$
$\sigma = 0.2$	0.066	0.035	0.018	0.013	0.010
$\sigma = 1.0$	0.033	0.018	0.014	0.014	0.008
$\sigma = 5.0$	0.037	0.023	0.017	0.014	0.011

The boldface value in table shows that the acceptable error is less than 0.05

Let us consider first the effect of λ with the following parameter setup

$$\mu = 1, \quad \sigma = 5, \quad \gamma_0 = 0.1, \quad \gamma_1 = 0.2, \quad \gamma_2 = 1.$$

Applying the approximation (34), we will provide values of Δ in Table 1.

To show the effect of σ Table 2 collects the Kolmogorov distance for the following parameters

$$\lambda = 1, \quad \mu = 1, \quad \gamma_0 = 0.1, \quad \gamma_1 = 0.2, \quad \gamma_2 = 1$$

with various values of the parameters N and σ .

Assuming an acceptable error $\Delta \leq 0.05$ of the given values in the Tables 1 and 2 we can conclude that the approximation (34) has large error at $N \leq 10$, at $10 < N < 20$ the acceptability of the approximation is doubtful, and at $N \geq 20$ the approximation has a quite acceptable accuracy. Let us notice that for fixed λ and σ the distance is decreasing as N is increasing, which was expected. However, for fixed N the distance is not a monotone decreasing function of λ and σ , respectively. We must emphasize that the system is too complicated to draw any conclusion to the approximation with respect to the parameters of the involved exponentially distributed random variables. Our expectation is that the distance should be a decreasing function of N , and we can illustrate the rate of convergence by sample examples.

Also for visual comparisons the discrete distribution of the number of customers in the system and the distribution function of the number of customers in the system at various N are provided. As an example for the graphical illustration of the accuracy of the approximation of exact (prelimiting) distribution (solid line) by Gaussian distribution (dashed line) with parameters $\kappa_1 N$ and $\kappa_2 N$, the following parameters were chosen

$$\lambda = 0.5, \quad \mu = 1, \quad \sigma = 5, \quad \gamma_0 = 0.1, \quad \gamma_1 = 0.2, \quad \gamma_2 = 1.$$

Comments

- In Fig. 2 we can see (a) the distribution of the number of customers in the system and (b) the distribution function of the number of customers in the system for $N = 5$. Figure 2b demonstrates a considerable difference between exact distribution $P(i)$

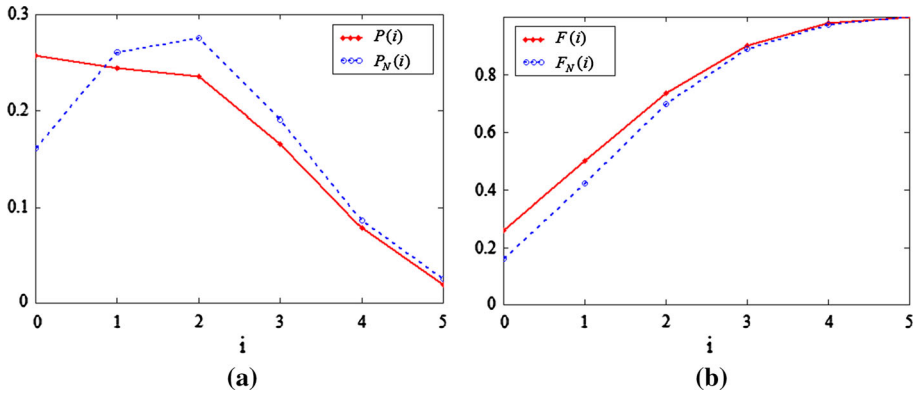

Fig. 2 Case $N = 5$

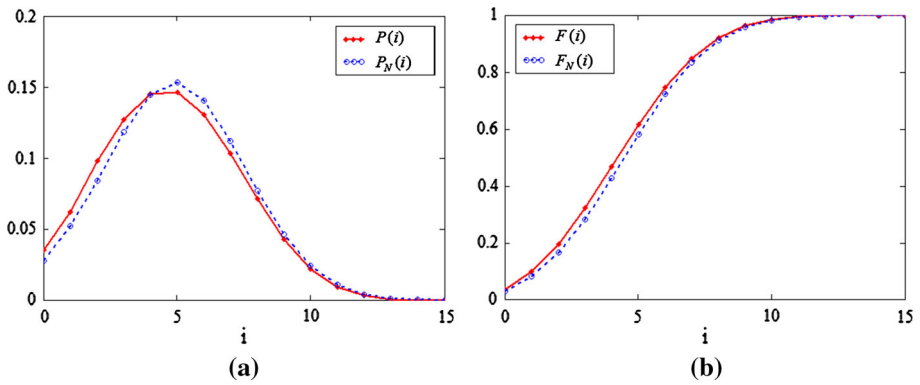

Fig. 3 Case $N = 15$

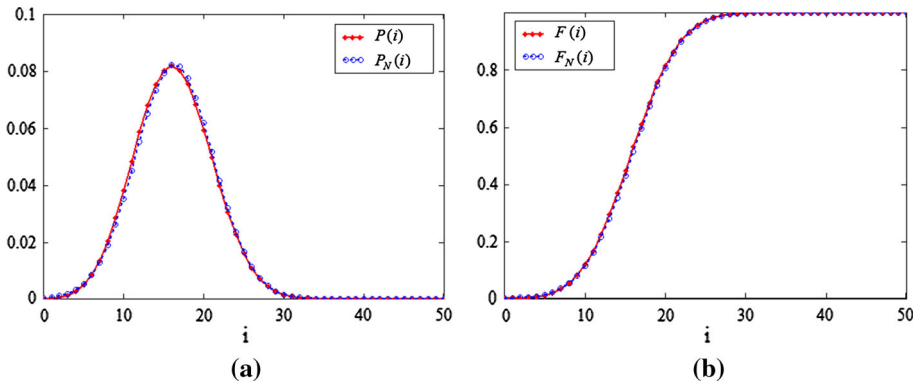

Fig. 4 Case $N = 50$

and its Gaussian approximation $P_N(i)$. Similar conclusions can be drawn regarding the distribution function $F(i)$ and its approximation $F_N(i)$, shown on Fig. 2b.

- Figure 3 demonstrates the results for $N = 15$. The differences are visible, but improvement of quality of the approximation with growth of N is obvious (Fig. 3a). For $F(i)$

and $F_N(i)$, shown in Fig. 3b, it is also possible to draw a conclusion on doubtfulness of applicability of the approximation.

- In Fig. 4a the results are displayed for $N = 50$. The difference is very slight and almost indistinguishable. It is possible to tell with confidence that the approximation has good degree of accuracy. Similarly, the distribution function $F_N(i)$ with good degree of accuracy approximates the exact distribution function $F(i)$ as shown on Fig. 4b.

The visual analysis is fully consistent with the conclusions drawn from Tables 1 and 2 and confirm the accuracy and the range of applicability of the proposed approximation. Here we could demonstrate the advantage of the approximation since the limiting distribution could be calculated very easily. In this case we are lucky because we could determine the exact distribution, but for complicated systems only sophisticated numerical or simulation approaches could be used. In those cases the approximation is more useful since the simulation needs long time.

8 Conclusion

In this paper, a finite-source retrial queuing system with collision of customers and an unreliable server was studied. The research of the system has been conducted by the method of asymptotic analysis under condition of unlimited growing number of sources. As a result of the investigation the Gaussian limiting distribution for the number of customers in the system was obtained in steady state. In addition, an algorithmic approach was introduced for calculating the prelimiting discrete distribution of the number of customers in the system. An approximation of the prelimiting discrete distribution by asymptotic Gaussian distribution was offered and illustrated. Accuracy and range of applicability of the approximations were shown in several sample examples for various values of the input parameters. The formulas received during the analysis are a basis for further research of the system, in particular for finding the distribution of the sojourn time of a tagged customer in the system and the distribution of the number of retrials.

Acknowledgements The authors are very grateful to the reviewers for their valuable comments and suggestions which improved the quality and the presentation of the paper. The publication was financially supported by the Ministry of Education and Science of the Russian Federation (The Agreement Number 02.a03.21.0008). The work of Tamás Bérczes was supported in part by the project EFOP-3.6.2-16-2017-00015 supported by the European Union, co-financed by the European Social Fund.

References

- Ali, A. A., & Wei, S. (2015). Modeling of coupled collision and congestion in finite source wireless access systems. In *Wireless communications and networking conference (WCNC), 2015 IEEE* (pp. 1113–1118). IEEE
- Almási, B., Roszik, J., & Sztrik, J. (2005). Homogeneous finite-source retrial queues with server subject to breakdowns and repairs. *Mathematical and Computer Modelling*, 42(5–6), 673–682.
- Arivudainambi, D., & Godhandaraman, P. (2015). Retrial queueing system with balking, optional service and vacation. *Annals of Operations Research*, 229(1), 67–84.
- Artalejo, J. R., & Gómez-Corral, A. (2008). *Retrial queueing systems. A computational approach*. Berlin: Springer.
- Bae, Y. H., Kim, K. J., Moon, M. N., & Choi, B. D. (2008). Analysis of IEEE 802.11 non-saturated DCF by matrix analytic methods. *Annals of Operations Research*, 162(1), 3–18.

- Balsamo, S., Dei Rossi, G. L., & Marin, A. (2013). Modelling retrieval-upon-conflict systems with product-form stochastic Petri nets. In *International conference on analytical and stochastic modeling techniques and applications* (pp. 52–66). Springer
- Choi, B. D., Shin, Y. W., & Ahn, W. C. (1992). Retrieval queues with collision arising from unslotted CSMA/CD protocol. *Queueing Systems*, 11(4), 335–356.
- Dragieva, V. I. (2014). Number of retrials in a finite source retrieval queue with unreliable server. *Asia-Pacific Journal of Operational Research*, 31(2), 23.
- Dragieva, V. I. (2016). Steady state analysis of the M/G/1/N queue with orbit of blocked customers. *Annals of Operations Research*, 247(1), 121–140.
- Gharbi, N., & Dutheillet, C. (2011). An algorithmic approach for analysis of finite-source retrieval systems with unreliable servers. *Computers & Mathematics with Applications*, 62(6), 2535–2546.
- Gómez-Corral, A. (2010). On the applicability of the number of collisions in p-persistent CSMA/CD protocols. *Computers & Operations Research*, 37(7), 1199–1211.
- Gómez-Corral, A., & Phung-Duc, T. (2016). Retrieval queues and related models. *Annals of Operations Research*, 247(1), 1–2.
- Ikhlef, L., Lekadir, O., & Aïssani, D. (2016). MRSPN analysis of Semi-Markovian finite source retrieval queues. *Annals of Operations Research*, 247(1), 141–167.
- Kim, J. S. (2010). Retrieval queueing system with collision and impatience. *Communications of the Korean Mathematical Society*, 25(4), 647–653.
- Kim, J., & Kim, B. (2016). A survey of retrieval queueing systems. *Annals of Operations Research*, 247(1), 3–36.
- Kumar, B. K., Rukmani, R., Thangaraj, V., & Krieger, U. R. (2010). A single server retrieval queue with Bernoulli feedback and collisions. *Journal of Statistical Theory and Practice*, 4(2), 243–260.
- Kumar, B. K., Thanikachalam, A., Kanakasabapathi, V., & Rukmani, R. (2016). Performance analysis of a multiprogramming-multiprocessor retrieval queueing system with orderly reattempts. *Annals of Operations Research*, 247(1), 319–364.
- Kumar, B. K., Vijayalakshmi, G., Krishnamoorthy, A., & Basha, S. S. (2010). A single server feedback retrieval queue with collisions. *Computers & Operations Research*, 37(7), 1247–1255.
- Kvach, A., & Nazarov, A. (2015). *Sojourn time analysis of finite source Markov retrieval queueing system with collision* (pp. 64–72). Cham: Springer.
- Nazarov, A., Kvach, A., & Yampolsky, V. (2014). *Asymptotic analysis of closed Markov retrieval queueing system with collision* (pp. 334–341). Cham: Springer.
- Nazarov, A., & Moiseeva, S. P. (2006). *Methods of asymptotic analysis in queueing theory*. Tomsk: NTL Publishing House of Tomsk University. (In Russian).
- Nazarov, A., & Sudyko, E. (2010). Method of asymptotic semiinvariants for studying a mathematical model of a random access network. *Problems of Information Transmission*, 46(1), 86–102.
- Peng, Y., Liu, Z., & Wu, J. (2014). An M/G/1 retrieval G-queue with preemptive resume priority and collisions subject to the server breakdowns and delayed repairs. *Journal of Applied Mathematics and Computing*, 44(1–2), 187–213.
- Roszik, J. (2004). Homogeneous finite-source retrieval queues with server and sources subject to breakdowns and repairs. *Ann. Univ. Sci. Budap. Rolando Eötvös, Sect. Comput.*, 23, 213–227.
- Wang, J., Zhao, L., & Zhang, F. (2010). Performance analysis of the finite source retrieval queue with server breakdowns and repairs. In *Proceedings of the 5th international conference on queueing theory and network applications* (pp. 169–176). ACM
- Wang, J., Zhao, L., & Zhang, F. (2011). Analysis of the finite source retrieval queues with server breakdowns and repairs. *Journal of Industrial and Management Optimization*, 7(3), 655–676.
- Zhang, F., & Wang, J. (2013). Performance analysis of the retrieval queues with finite number of sources and service interruptions. *Journal of the Korean Statistical Society*, 42(1), 117–131.